



















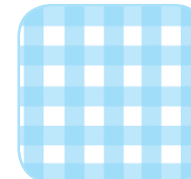
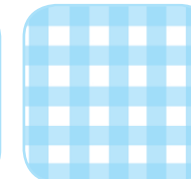

- Przyjrzyj się rytmom. Umieść brakujące nalepki w odpowiednich miejscach. Odtwórz rytmy pokazane na rysunkach. W pustych okienkach narysuj swój rytm i zaprezentuj go kolegom i koleżankom.

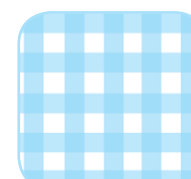
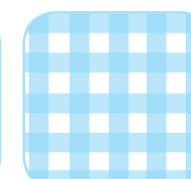
- Przyjrzyj się zdjęciom. Otocz niebieskimi pętlami instrumenty, w które trzeba dmuchać, by wydobył się z nich dźwięk. Otocz czerwonymi pętlami instrumenty, które mają struny.
- ★ Powiedz, jak nazywają się instrumenty pokazane na zdjęciach.



- Podziel na sylaby nazwy instrumentów pokazanych na zdjęciach. Otocz pętlami tyle nut pod każdym zdjęciem, ile sylab ma dana nazwa.

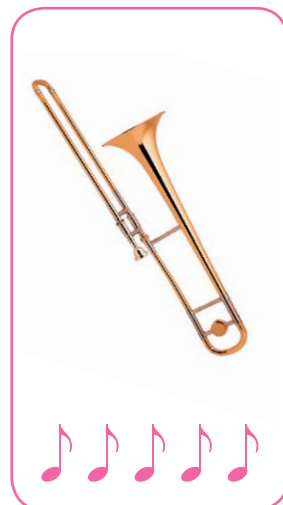

- Znajdź i otocz pętlami parę takich samych marakasów. Ile marakasów nie ma pary? Pokoloruj okienko z właściwą liczbą.

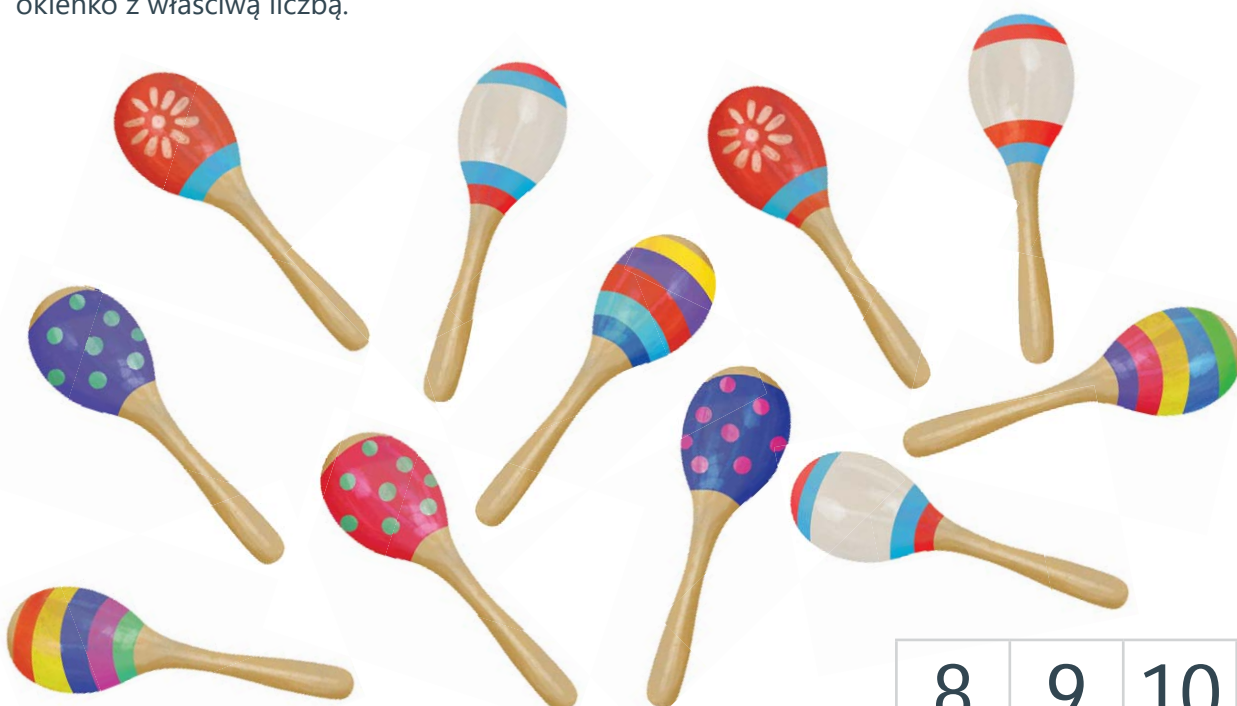

8	9	10
---	---	----

- Pokoloruj dzieciom ubrania – na czerwono te, których nazwy zaczynają się głóską *s*, a na niebiesko te, których nazwy zaczynają się głóską *b*. Powiedz, ile widzisz instrumentów na rysunku, i narysuj w ramce na dole strony odpowiednią liczbę kropek.

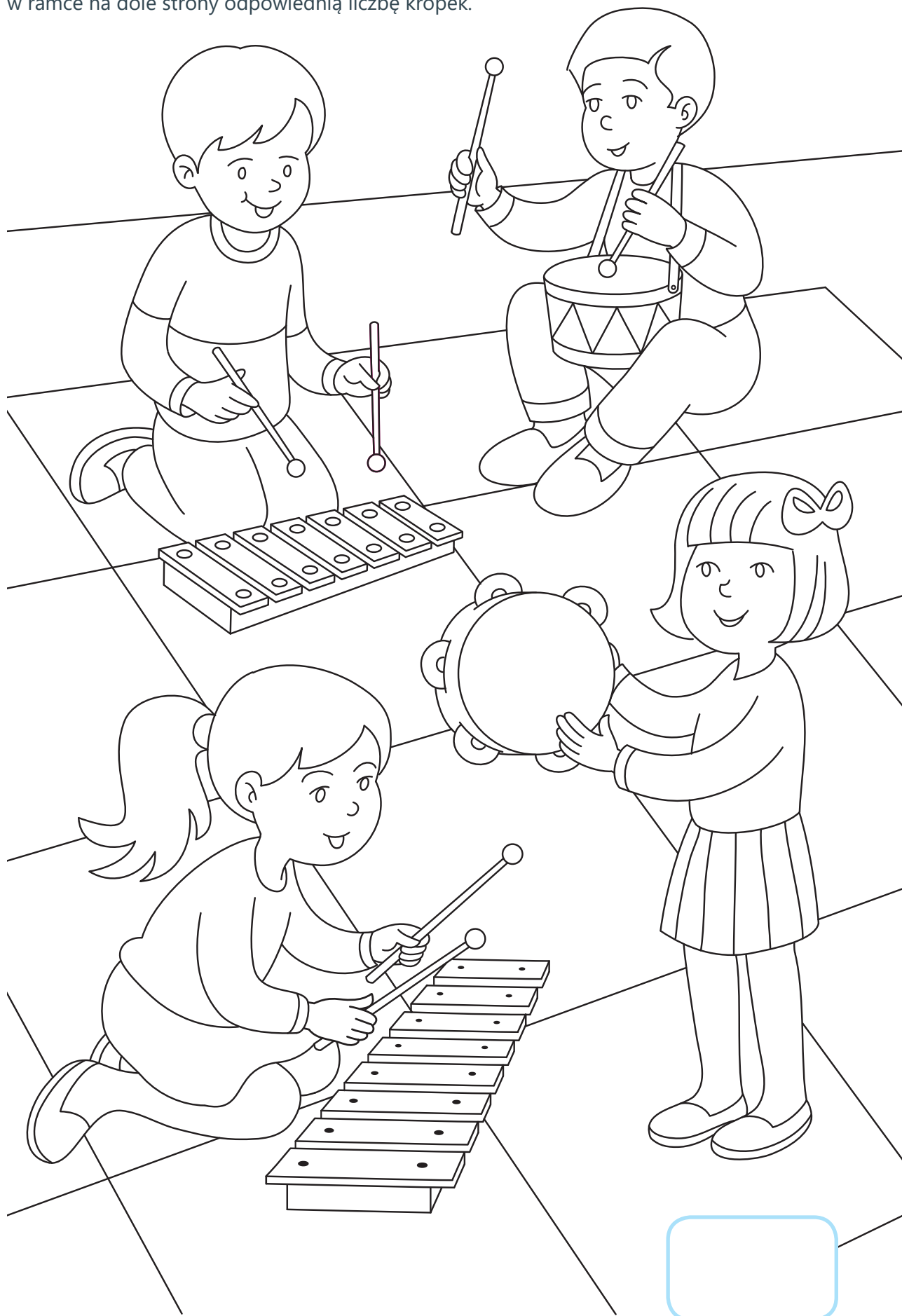

• Narysuj obrazek.

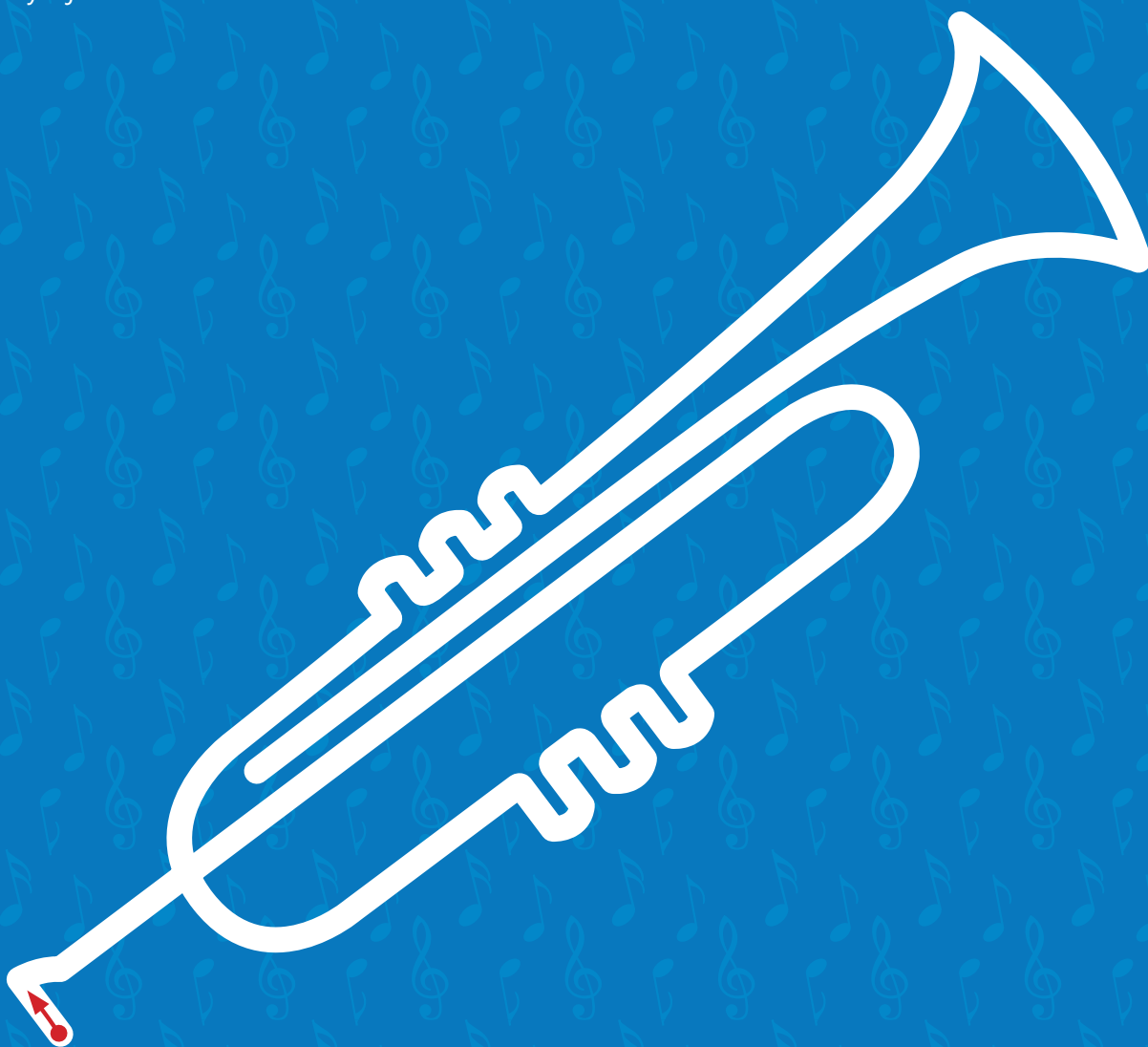

• Narysuj szlaczki po śladzie.



- Do każdego instrumentu został dobrany jeden kolor. Pokoloruj poniższe pola kolorami, które odpowiadają kolejnym usłyszonym instrumentom.



- Narysuj skrzypce oburącz.



- Przyjrzyj się rysunkowi. Policz, ile jest na ilustracji wskazanych instrumentów. Narysuj w kółkach na dole strony odpowiednią liczbę kropek.
- ★ Powiedz, jak nazywa się każdy z instrumentów na obrazku.



Hh

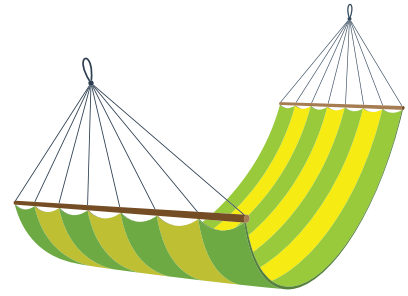

hamak

- Znajdź na ilustracji i otocz pętlami wszystkie litery **H, h**.



- Narysuj szlaczek po śladzie.



- Umieść nalepki z literami we wskazanych miejscach i przeczytaj powstałe słowa. Połącz liniami wyrazy z odpowiednimi zdjęciami.



ak



ak



ak



- Przyjrzyj się zdjęciom i powiedz, co przedstawiają. Pod każdym zdjęciem pokoloruj tyle kwadraczków, ile sylab słyszysz w każdej nazwie.

hamak



hulajnoga



helikopter



hydrant



- Połącz linią każdą ilustrację z numerem wysłuchanego utworu.



1

2

3

4

5



- Pokoloruj rysunek zgodnie z kodem na dole strony, a dowiesz się, jaki instrument często znajduje się w dziecięcym pokoju.

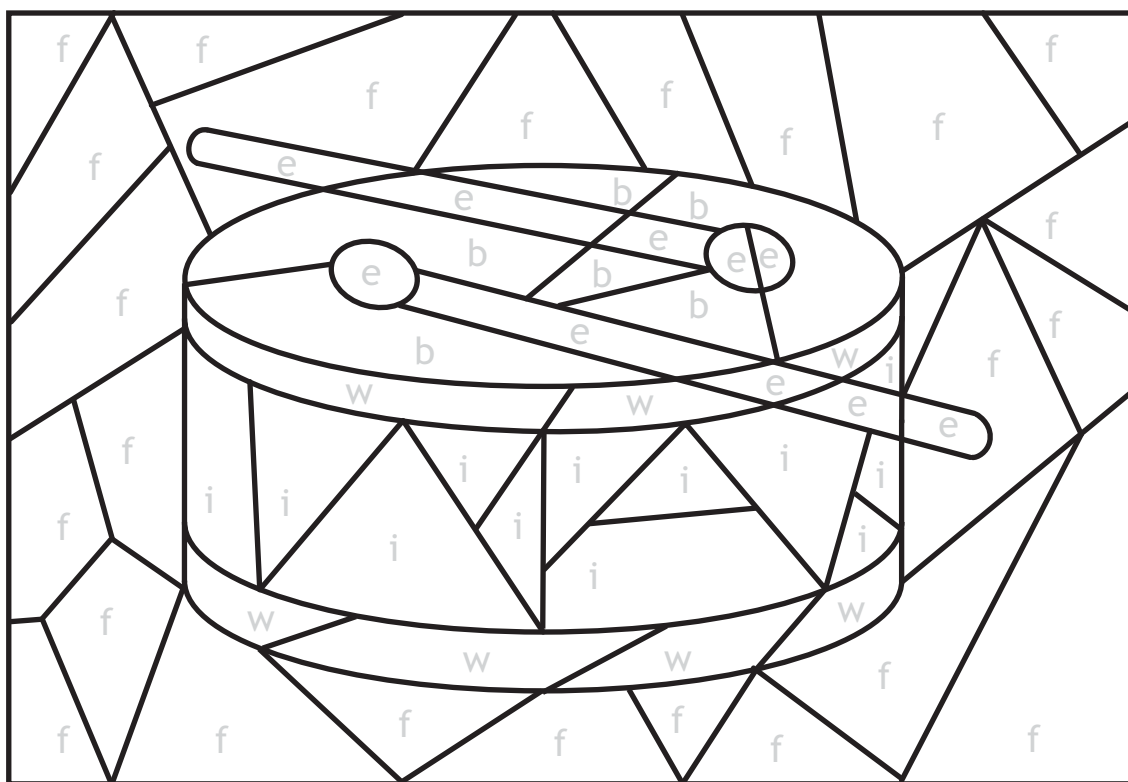

- Znajdź 10 różnic między obrazkami. Otocz różnice pętlami na dolnym rysunku.

